

C3570 checkweigher

Configurable to Suit Any Application



Straightforward operation and simple integration

into production lines. Smooth processes, maximum uptime and trouble-free refitting further down the line – thanks not only to our future-proof system architecture designed with practical scenarios in mind, but also our perfectly customised checkweigher configurations.



Up to 33% higher performance

Don't let anything stand in the way of increasing production line throughput. The C3000 system combines high throughput with the utmost accuracy to promote tighter manufacturing tolerances in your production facility. Improved processes mean an increase in overall equipment effectiveness to maximise your profits.



Lower total cost of ownership

Here, a solid design and long service life are what counts. Under the harsh conditions of everyday production, it pays dividends to use machines that are both sturdy and robust. Fewer wear parts, a smaller spare parts inventory and less downtime all result in increased productivity.



"Built-in" safety plus

It's a great feeling to know that you're not only meeting legal requirements, but also the guidelines and standards of customers worldwide. From product transport to sorting equipment – every last component has been put to the test, not to mention every potentially hazardous area. As a result, the potential for material damage and injury is significantly reduced.



C3570 – the ideal solution for products up to 10 000 grams

Whether you're working with oval cans, flat bags, rectangular boxes or even square ones, the C3570 checkweigher uses outstanding precision and speed to weigh products in all types of packaging. In addition to its large product setup memory, it stands out from the crowd thanks to its ability to be integrated into production lines with ease, variety of data communication interfaces and wide range of options.

The optional "filling head test" lays the foundations for optimising filling processes, and you can even switch the display from "ml" to "l" with the "volumetric filling" option. With scaling options to suit your configuration, this checkweigher can be customised to perform a wide variety of different tasks.

C3570

Technology of the future – today

200 product setup memories allow you to change quickly to a different item when changing over production. Counter readings for each zone plus "total count" give you an overview, while the weight classification allows for sorting functions.

C3570 basic configuration

- 15-inch touchscreen terminal with emergency-off switch and USB port
- Conveyor belts (see dimensions table)
- Air jet
- Chute (no catch bin)

Performance features

- Weighing cell according to the electromagnetic force restoration principle; digital, maintenance-free, temperature-stable
- Design approved for official verification
- Reference value $e \geq 0.1$ g up to 1 kg product weight
- Reference value $e \geq 0.2$ g up to 10 kg product weight
- Number of steps approved for official verification (dynamic) $n \leq 2 \times 10000$
- Conveyor belt speed $V_{max} \leq 3$ m/sec.
- Multi-interval capacity for optimal coverage of the weighing range thanks to various optimised resolutions
- Classification into three weight zones (or up to seven as an option)
- Automatic or manual re-zero
- Flexible integration into production lines
- Individual user profiles with password protection
- Floating outputs for "Checkweigher ready for operation" and "Conveyor belts in operation", designed as changeover relays
- Temperature range 0 - 40°C (different temperature ranges available in the case of special designs)
- IP54 protection against water
- 115/230 V~, 50/60 Hz, 1 phase, 500 VA
- Approval no. DE-07-MI006-PTB037

Weighing terminal

- Various switchable program languages
- Product setup memory for up to 200 items
- 15-inch colour touchscreen TFT display, resolution 1024 x 768 pixels (XVGA)
- User-friendly: TachoControl, menu navigation, user profiles
- Display of all key up-to-date weighing data and production/configuration screens
- Windows-based, embedded standard 2009 control system

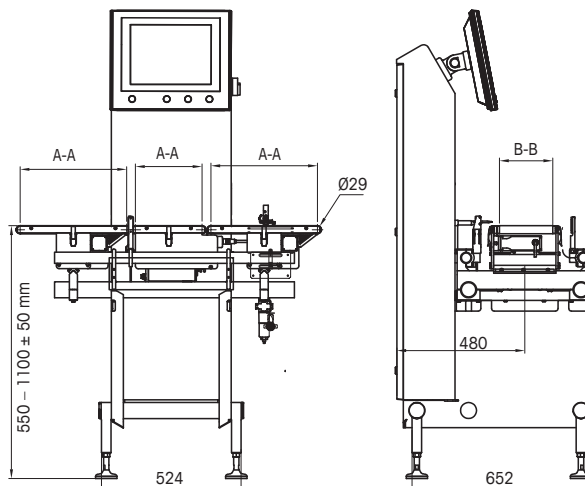

Schematic – typical dimensions in mm (A-A, B-B vary depending on the conveyor size)

Mechanical options

- Various infeed units and several infeed/outfeed conveyors, such as sidegrip belts or a mechanical transfer unit
- Nose roller for conveyor belt transition area
- Various sorting/rejecting devices such as pusher and lift gate
- Cover (safeguard)
- Catch bin
- IP65 protection against water
- Granulate-proof conveyors
- D15 'highest weighing accuracy' conveyors

Electronic options

- Automatic filling process control (feedback control with up to 6 controllers)
- Filling head test
- Tare gross weighing
- Login server (system access logging)
- Statistics and evaluation programs
- Statistical process monitoring (SPM)
- PrintStick or printer
- Various types of monitoring equipment (e.g. product backup detection)
- Metal detector input
- OPC server properties
- Various interfaces (e.g. for weight data)
- Fieldbus interface module
- Interface to the METTLER TOLEDO FreeWeigh.Net® or ProdX SQC system
- Volumetric filling (display in ml or l)
- Other special accessories on enquiry

Technical data

Technical data	C3570
Weighing range*	configured according to product weight in the range of 0 to 10000 g
Accuracy**	from ± 0.1 g
Throughput (weighings/minute)**	max. 600
Distance between roller centres (A-A) of weighing conveyor, in mm	150, 200, 250, 300, 400, 500, 600
Belt width (B-B) of weighing conveyor*** in mm	120, 150, 200, 250, 300, 400
Distance between roller centres (A-A) of infeed and outfeed conveyor in mm	250, 300, 400, 500, 600, 800, 1000, 1200, 1500, 1800
Belt width (B-B) of infeed and outfeed conveyor in mm	120, 150, 200, 250, 300, 400
Standard sorting/rejecting equipment	air jet

* Depending on design and dimensions of the weighing conveyor in use

** Within official margins of error, depending on weight, dimensions and running behaviour of the product being weighed

*** Availability depending on selected conveyor type (e.g. D15 "highest weighing accuracy" conveyors)



Mettler-Toledo Garvens GmbH

Kampstrasse 7
31180 Giesen, Germany
Telephone +49 (0) 5121 933-0
Facsimile +49 (0) 5121 933-456
e-mail garvens@mt.com

Subject to technical modifications.

© Mettler-Toledo Garvens GmbH, 31180 Giesen, Germany

Printed in Germany 0614/188 EN

www.mt.com/garvens

For more information